

M5 Series

Digital Smart Locks



Elegance and convenience

Smart features and functions whilst not
compromising on security



A new era in smart, modern security



Change the way you think about home security and upgrade to a dormakaba digital door lock with the new M5 Series BLE smart locks. Allowing you to unlock your door with a PIN, an RFID Card/Fob, a key or a Smart phone via Bluetooth.

Designed with elegance, matched with the convenience of the smart features and functions whilst not compromising on security, reliability and performance. Giving you the ultimate control of your home security.



Bluetooth features

The M5 Series as standard offers Bluetooth features that provide the ability to unlock your door, retrieve data logs and more all from your smart phone via the dormakaba smart lock app (iOS & Android).

Ease of installation & Voice guided programming

As a standalone unit, the M5 Series requires no additional wiring, providing a quick and easy installation for new or existing homes. With the assistance of step by step voice guided programming, setting up and maintaining the M5 Series is as simple as entering the Administrator PIN and following the voice prompts. An RFID Card/Fob can be added as Administrator once programmed.



Ultimate control for you

Designed with elegance, matched with the convenience of the smart features and functions whilst not compromising on security, reliability and performance. Giving you the ultimate control of your home security.

The M5 comes standard with 2 proximity cards, 2 fobs, 3 keys and BLE connectivity. Additional cards/fobs are available from your local M5 distributor.

With the assistance of step by step voice guided programming, setting up and maintaining the M5 is as simple as entering the administrator PIN and following the voice prompts. An RFID Card/Fob can be added as Administrator once programmed.

Advantages at a glance:

- Mobile access
- Digital touch pad
- Battery powered
 - no need for wiring
- Voice guided programming
- Programmable administration code/card registration
- Up to 100 RFID Cards
 - 70 general users
- 10 Pin codes
 - 7 general users
- Visitor friendly with optional passage mode
- Wrong try lock-out delay
- Low battery alert & external emergency power supply
- Mechanical key override
- Fire rated

Peace of mind

smart, visitor access



Remote Code Sharing providing time sensitive remote access

In Bluetooth mode, the dormakaba Smart lock app allows the administrator to generate a pin code for a visitor/short term stay guest according to specific time periods. These can then be shared via multiple methods of media, such as email or text messages.

Peace of mind with Security assured

No need to add additional locking devices to the door.

The M5 Series is supplied as standard with the Australian style dormakaba MS2602 Series mortice lock providing the reassurance in knowing that by exceeding the highest levels of Australian standard for both mechanical security and durability (AS4145.2) the M5 Series is truly the best solution for any digital locking solution.



Dimensions

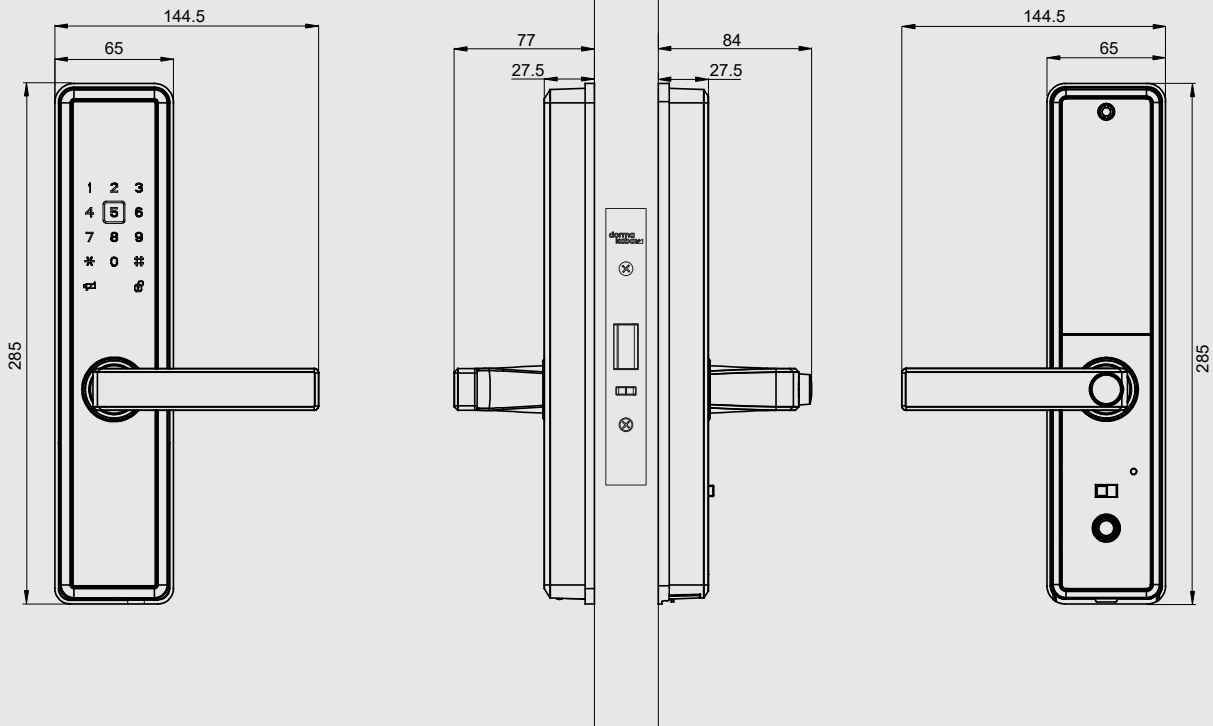

App download links



App Store



Google

Specifications

Hardware		Zinc Alloy
Finish and colour	Black with Matt Black rim Black with Brushed Nickle rim	
Keypad	Illuminated 12 keys	
Mortise type	Australian style, 60mm backset EN Mortise	
Storage		
Card key	100	
Card configuration	2 large cards (RFID cards) 2 small cards (fobs)	
Pin code	10	
Mechanical key override	3 keys included	
BLE devices	10	
Enrolment and verification		
M5 model	Smart lock APP, RFID card key/tag, pin code, mechanical key override	
Verification time (sec)	≤1s	
Length of pin code	6-12 digits	
App Specification		
Platform	iPhone (iOS 8.0 and above) Android-based Smart phone (Android 5.0 and above)	
Language	English and Chinese	
Verification methods	Password, pattern and fingerprint* (if the smartphone is equipped with fingerprint sensor)	
Device management	Add/delete/modify device, Information checking and notification	
Functions	Open/close lock, time sync, key sharing and audit trail	
Fire Rating		
	M5 Series has been successfully tested on fire door assemblies in accordance with AS1905 Part1: Fire resistance doorsets.	
Notes:		
1. Doors in an escape path require free egress and lever furniture to allow escape in direction of travel.		
2. Compatibility for use with varying fire door cores should be checked with dormakaba.		

Colour options

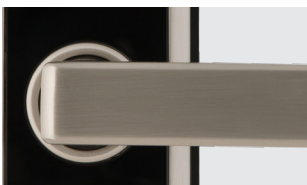

Black with Brushed Nickel rim



Black with Matt Black rim

Operating Environment	
Temperature (°C)	-20 to +55
Humidity (%)	0 to 90%, non condensing
Weather protection	IP54
Lock Features and Functions	
Power input	4 x 1.5V AA Alkaline battery
Voice prompt	Voice guidance in English/Chinese
Low battery alarm	Yes
Break-in and tamper alarm	Yes
Wrong pin code lockout alarm	Yes
Passage mode	Yes
One-time password	Yes
Password sharing	Yes
Scramble password	Yes
Unclosed door warning	Yes
Optional features	Safety handle design BLE function
Backup unlock mechanism	External emergency battery or mechanical key
Door thickness	35mm - 50mm
Dimensions	
External body	65 x 285 x 27.5 mm (W x H x D)
Internal body	65 x 280 x 27.5 mm (W x H x D)



External lock body



Internal lock body



**Door
Hardware**



**Entrance
Systems**



**Electronic
Access & Data**



**Interior Glass
Systems**



**Lodging
Systems**



**Mechanical
Key Systems**



Safe Locks



Services

Our Sustainability Commitment

Our sustainability commitment. We are committed to fostering a sustainable development along our entire value chain in line with our economic, environmental and social responsibilities toward current and future generations. We seek an open, transparent dialogue with all stakeholders to define strategies and actions based on clear targets and continuous improvement, and we actively report on our progress.

DDL-The Grange Brochure-AU-NZ-MAR 2023DDL00011.
Subject to technical alterations.

dormakaba Australia

Head Office
12-13 Dansu Court
Hallam VIC 3803
T 1800 675 411
info.au@dormakaba.com
www.dormakaba.com.au

dormakaba New Zealand

Building P 61-69 Patiki Road
1026 Avondale/Auckland
New Zealand
T: 0800 436 762
info.nz@dormakaba.com
www.dormakaba.com.au